

# **WORKSHOP MANUAL**

---

***VW-Porsche***

***D-Jetronic***

---

**ROBERT BOSCH**

# CONTENTS

<b>How to use this Manual</b> .....	<b>221</b>
<b>Fuel System Description</b> .....	<b>222</b>
<b>Air System Description</b> .....	<b>223</b>
<b>Electronic System Description</b> .....	<b>224</b>
<b>Functional Description</b> .....	<b>225</b>
<b>Wiring Harness Description</b> .....	<b>226</b>
<b>Trouble-Shooting Chart</b> .....	<b>228</b>
<b>Component Removal and Replacement</b> .....	<b>231</b>
<b>Test Chart</b> .....	<b>238</b>
<b>Ignition and Idle Adjustments</b> .....	<b>247</b>
<b>Service Parts List</b> .....	<b>248</b>

This manual is designed to assist you in the trouble-shooting and repair of vehicles with the Robert Bosch D-Jetronic (EFI) System using mostly common workshop tools. You should understand this fuel injection system before you begin working on the vehicle. The Bosch Technical Instruction Booklet VDT-UBP 751/1B explains the D-Jetronic System in detail and will increase your understanding of this system. This will reduce repair times and facilitate the use of this Workshop Manual.

## HOW TO USE THIS MANUAL

This manual is designed to instruct the technician unfamiliar with Robert Bosch fuel injection systems to locate faults in the system, isolate the component involved, and test the component for correct function. You will need a volt-ohm meter and a pressure gauge as well as the normal workshop tools. All measurements are made at the terminals of the large plug at the end of the wiring harness after it is removed from the control unit. Most components of this system cannot be repaired and will have to be replaced once you have determined them defective.

If you are already familiar with the Bosch D-JETRONIC system and can identify and locate all the components in the vehicle, you can go directly to the Trouble-Shooting Chart to track down the faulty component. Then test that component according to the Test Chart.

If this fuel injection system is new to you, start with the Fuel, Air and Electronic System Descriptions, then read the section "Functional Description."

The section entitled "Component Removal and Replacement" will help you locate each component in the vehicle. Then you can consult the Trouble-Shooting Chart for the symptoms found on the vehicle in question. This will tell you what to check on the vehicle and direct you to the section of the Test Chart where the suspected component is checked for correct function.

The last section of the manual, "Ignition and Idle Adjustments," describes the timing and idle speed/mixture settings which should be checked after every repair and before the car is returned to the customer. Finally, a Service Parts List gives you the part numbers for seals, gaskets, plugs, etc., which you will need for replacement purposes.

# FUEL SYSTEM DESCRIPTION

Fuel is drawn from the tank via the fine filter ① by an electric fuel pump ② and forced into the pressure line ③. The ring main ④ which is connected to the pressure line routed in the frame provides the four injection valves ⑤ with fuel. The pressure regulator ⑥ maintains the pressure in the ring main at  $2 \text{ kgf/cm}^2$  (28.5 psi). From here, the surplus fuel can flow back to the tank through the (pressureless) line ⑦. The bypass return line coming from the fuel pump also leads into this line.

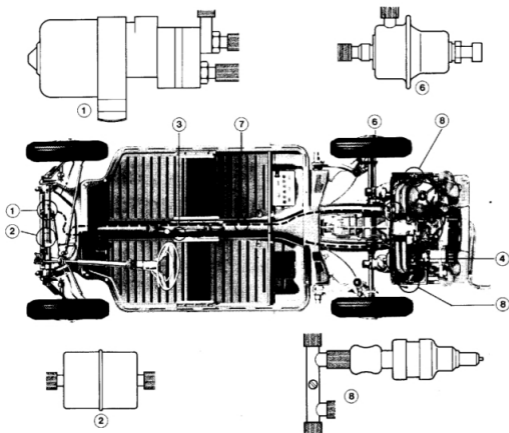



# AIR SYSTEM DESCRIPTION

Four intake tubes ①, which are connected to the intake manifold ④, supply the four cylinders with air. A pressure switch ②, a pressure sensor ③ and the vacuum advance of the ignition distributor are also connected to the intake manifold.

The pressure switch reacts to the difference between the pressure in the intake manifold and the atmospheric pressure, whilst the pressure sensor measures the actual pressure in the intake manifold (evacuated aneroids).

There is a throttle valve, operated by the accelerator

pedal via a bowden cable, at the mouth of the intake manifold. The intake manifold is connected to the air filter ⑤ by a rubber hose elbow ⑥.

The idle-air system is in the form of a bypass system in the intake manifold. It joins behind the throttle valve. Its functional cross section can be varied with the idle adjustment screw ⑭ (idle adjustment). An auxiliary air line from the air filter via the auxiliary-air device ⑮ to the intake manifold forms the warm-up air system. Its effective cross section is varied, depending on the engine temperature, by the auxiliary-air device.

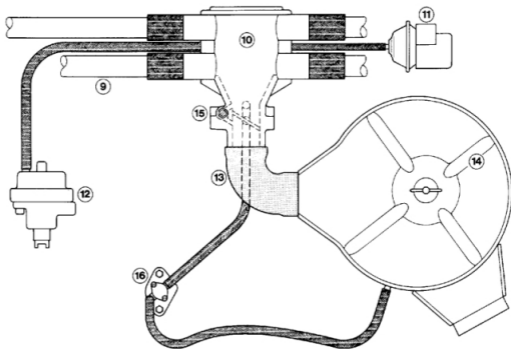

- ① Intake tubes
- ④ Intake manifold
- ② Pressure switch
- ③ Pressure sensor
- ⑪ Elbow
- ⑤ Air filter
- ⑭ Idle adjustment screw
- ⑮ Auxiliary-air device (rotary valve)

# ELECTRONIC SYSTEM DESCRIPTION

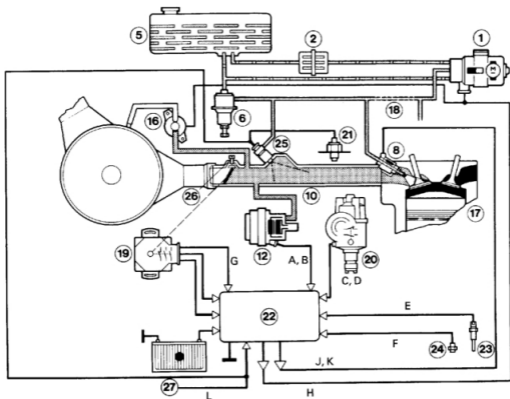

## Key to schematic of system

- ① Fuel pump
- ② Fuel filter
- ③ Fuel tank
- ④ Pressure regulator
- ⑤ Solenoid-operated injection valve
- ⑥ Intake manifold
- ⑦ Pressure sensor with full load enrichment
- ⑧ Auxiliary-air device with electrical heating in VW-Porsche 914.
- ⑨ Cylinder head
- ⑩ Fuel distribution pipes to the injection valves
- ⑪ Throttle valve switch with momentary enrichment
- ⑫ Ignition distributor with trigger contacts
- ⑬ Thermo-time switch
- ⑭ Electronic control unit (ECU)
- ⑮ Temperature sensor I in intake air distributor
- ⑯ Temperature sensor II in cylinder head
- ⑰ Cold-start valve
- ⑱ Idle adjustment screw
- ⑲ From starting motor terminal 50

## Information for the electronic control unit

Information	Signal
A, B Pressure sensor	Load condition of the engine
C, D Trigger contacts of ignition distributor	Engine speed, triggering signal for start of injection
E Temperature sensor I (intake manifold)	Correction of injected quantity, dependent on air temperature in the intake manifold
F Temperature sensor II (cylinder head)	Warm-up
G Throttle valve switch	Temporary enrichment and gasoline shut-off during overrun
H To fuel pump and auxiliary-air device	
J, K To injection valves	
L From starting motor terminal 50 when thermo-switch simultaneously closed	Start enrichment (cold-start valve)

# FUNCTIONAL DESCRIPTION

Fuel is drawn from the tank (1) via the filter (2) by the fuel pump (3), and forced into the ring main.

The pressure regulator (4), connected to the end of the ring main, limits the pressure of the fuel to 28.5 psi (2 kgf/cm<sup>2</sup>). The solenoid-operated injection valves (5) are connected to the ring main via fuel distribution pipes (6). From the pressure regulator, surplus fuel can flow through a return line in the frame tunnel back to the tank.

The bypass return line coming from the fuel pump leads into this line. There is a relief valve in the fuel pump, which comes into operation when the pressure rises considerably above the nominal value as, for example, could occur should the pressure regulator (4) develop a defect. A non-return valve in the pressure line connection of the fuel pump prevents the pressure in the ring main from dropping immediately when the pump is switched off. The injection valves (5) are opened electrically in two pairs (J and K) by the electronic control unit and, due to the fuel pressure, fuel is injected. The nozzle duct of the injection valve is accurately calibrated. Since the fuel pressure is kept constant, the injected fuel quantity is dependent only on the length of time the injection valve is kept open.

This injection time is "computed" by the electronic control unit. The "data" or information processed by the electronics in the control unit comes from the individual sensors on the engine. This is done in the following manner:

The moment when the fuel is injected is controlled by the distributor contacts (trigger contacts) I and II (C and D) according to the position of the camshaft. These contacts are installed under the centrifugal advance device in the distributor and are maintenance free.

The injection duration (fuel quantity) is governed basically by two factors: by the engine speed and the load condition of the engine. The engine speed is relayed to the control unit by the distributor contacts I and II. The load condition (part load or full load) is indicated by the pressure in the intake manifold. The prevailing pressure here is converted to an electrical impulse and also relayed to the control unit (A and B) by the pressure sensor (7) which is connected to the intake manifold (8) by a hose. The electronic control unit processes this information and gives a signal for the injection valves to be opened for a longer or shorter period of time (J and K). The control unit thus allows more or less fuel to be passed through the solenoid-operated injection valves depending on the engine load and the engine speed. This is how the "basic quantity of fuel" is determined. In addition to the "basic quantity of fuel", an accurately metered quantity of fuel is injected additionally (enrichment) when starting at low outside temperatures, when the engine is warming-up and at full load.

The starting enrichment of the air/fuel mixture is dependent on the engine temperature which is measured electrically by two temperature sensors, one in the crankcase and the other on the cylinder head (E and F). Starting enrichment may only take place when the starting motor is operated. The information as to when the starting motor is operating is relayed to the control unit via a cable which is connected to terminal 50 of the starter solenoid switch.

This information, too, is processed by the control unit in relation to the basic quantity of fuel and the impulses are relayed electrically to the fuel injection valves. The same principle applies during overrun (braking with the engine): in this case no fuel must be injected.

This operational condition is characterized by a closed throttle valve and increased engine speed. The throttle valve switch (G) switches off the fuel supply during overrun, when the vehicle speed is above 1,800 rev/min. If, during overrun, the speed drops to 1,250 rev/min the fuel supply is switched on again so that a smooth transition to idle operation is guaranteed.

To keep the electronic control unit as simple as possible, and the cost of the unit as low as possible, the fuel injection valves are parallel connected into groups of two (group 1 = cylinders 1 + 4; group 2 = cylinders 2 + 3).

Both fuel injection valves of one group inject fuel at the same time. The injection valves of cylinders 1 and 3 inject fuel past the open intake valves, into the combustion chamber during the inlet stroke, whilst the injection valves of cylinders 2 and 4 inject onto the still closed intake valves while the exhaust gases are being forced out. In this latter case the fuel is "stored" at the intake valves.

The amount of air is controlled during vehicle operation by the throttle valve in the intake manifold.

When idling, the throttle valve is completely closed.

The idle air can reach the intake tubes only via the bypass system in the intake manifold. The idle speed is adjusted by altering the cross section of the bypass system. For this purpose there is an adjusting screw and lock nut on the intake manifold.

The adjustment must be carried out only with the engine at operating temperature.

The engine, if it has not reached operating temperature, requires an additional amount of air. This is controlled by the auxiliary-air device (rotary valve). It alters the effective cross section of the auxiliary air pipe in accordance with the oil temperature. The position of the rotary valve is controlled by a bimetal spring which protrudes into the crankcase. At -30 °C (-22 °F) the rotary valve is open and at +50 °C (122 °F) it is fully closed.

# WIRING HARNESS DESCRIPTION

**Remark:**

The individual cables are marked with the corresponding cable number. These cable numbers are printed about 3/8" to 3/4" from each cable end.

Cable Number	From	To	Cable Number
1	electronic control unit	temperature sensor I (intake manifold)	1
2	not used		
3	electronic control unit	injection valve cyl. 1	3
4	electronic control unit	injection valve cyl. 4	4
5	electronic control unit	injection valve cyl. 2	5
6	electronic control unit	injection valve cyl. 3	6
7	electronic control unit	pressure sensor	7
8	electronic control unit	pressure sensor	8
9	electronic control unit	throttle valve switch	9
10	electronic control unit	pressure sensor	10
11	electronic control unit	ground (on crankcase)	11
12	electronic control unit	trigger contact in ignition distributor	12
13	electronic control unit	temperature sensor I (intake manifold)	13
14	not used		
15	electronic control unit	pressure sensor	15
16	electronic control unit	main relay terminal 87	16 (via plug housing T 1)
17	electronic control unit	throttle valve switch	17
18	electronic control unit	starting motor terminal 50	18 (via plug housing T 1)
19	electronic control unit	pump relay terminal 85	19 (via plug housing T 1)
20	electronic control unit	throttle valve switch	20
21	electronic control unit	trigger contact in ignition distributor	21
22	electronic control unit	trigger contact in ignition distributor	22
23	electronic control unit	temperature sensor II (cylinder head)	23
24	electronic control unit	main relay terminal 87	24 (via plug housing T 1)
25	not used		
26	injection valve cyl. 1	ground } on crankcase	26
27	injection valve cyl. 2		27
28	injection valve cyl. 3		28
29	injection valve cyl. 4		29
30	throttle valve switch terminal 14		30
31	cold-start valve	starting motor terminal 50	31 (via plug housing T 1)
32	cold-start valve	thermo-switch	32
47	throttle valve switch	ground on crankcase	47 (as from 8.71)

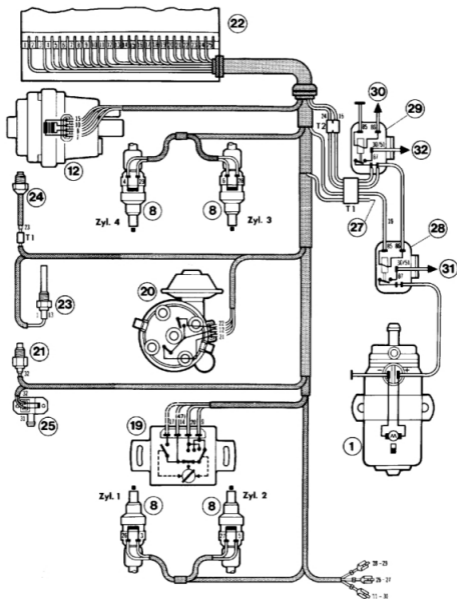

- ① Electric fuel pump
- ② Solenoid-operated injection valve
- ③ Pressure sensor
- ④ Throttle valve switch with momentary enrichment
- ⑤ Ignition distributor with trigger contacts
- ⑥ Thermo (-time) switch
- ⑦ Electronic control unit/ECU
- ⑧ Temperature sensor I in intake manifold
- ⑨ Temperature sensor II in cylinder head
- ⑩ Cold-start valve
- ⑪ Cables 18 and 31 from starting motor terminal 50
- ⑫ Pump relay

- ⑬ Main relay
- ⑭ To ignition switch terminal 15 (fuse box)
- ⑮ To fuse box terminal 30
- ⑯ To battery
- T<sub>1</sub> Printed-circuit board plug connection
- T<sub>2</sub> Cable connector

# TROUBLE-SHOOTING CHART

Engine has no power

With engine cold, adjust valves as accurately as possible according to instructions.

With engine warm, set dwell angle and ignition point accurately according to instructions. Sufficient power?

No

yes

Check spark plugs, interference suppression resistors, distributor rotor, ignition cables, distributor cap, contact points, condenser and ignition coil. All in order?

Yes

No

Replace defective parts.

Compression pressure and pressure drop correct?

Yes

No

Examine engine for mechanical faults.

Air filter clogged?

No

Yes

Clean or replace air filter. Check if correctly fitted.

Throttle plate fully open at full throttle?

Yes

No

Adjust throttle valve cable.

All hoses to pressure sensor and intake manifold connected correctly and air tight?

Yes

No

Check hoses and replace if necessary.

With engine running, check fuel pressure. Nominal value: 2 ... 2.2 kgf/cm<sup>2</sup>.  
Replace defective parts (e. g. pressure regulator or clogged fuel filter).

Check injection system. In order?

Yes

No

Replace defective parts.

With stroboscopic timing light check vacuum advance (in the case of ignition distributors with double vacuum units also check retarded ignition). All in order?

Yes

No

Clean vacuum holes. Check if vacuum holes are completely clear when throttle valve is closed. If throttle valve fully or partly covers a hole, replace air throttle assembly. Check vacuum and vacuum hoses.

Let engine run at 2000 rev/min. Check voltages at terminal 15 of ignition coil and terminal 87 on main and pump relays.

All in order?

Yes

No

Eliminate contact resistances. (Check battery terminals and connections to battery and engine).

Check electronic control unit and pressure sensor

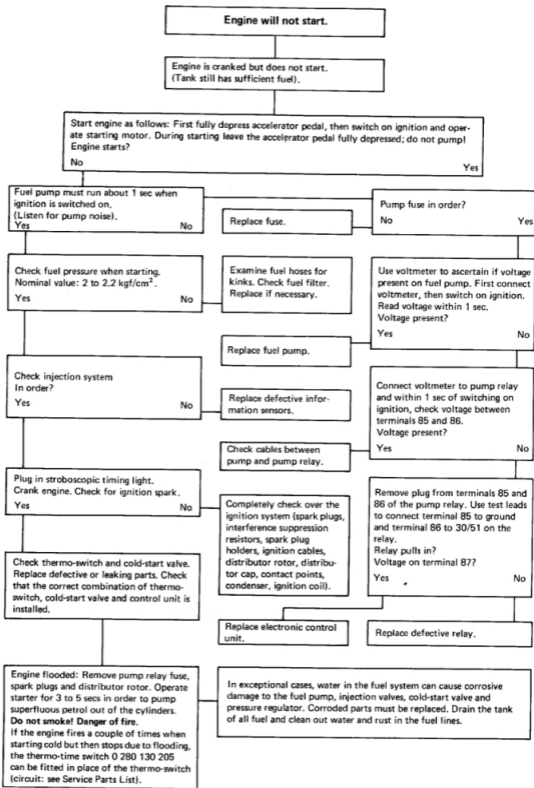

**Fuel consumption excessive.**

Enquire from driver about his operation of the vehicle and whether it is used for local town journeys or for longer distances.

Adjust engine valves with greatest possible precision and exactly to specification. Test compression loss.  
**Engine must be absolutely cold.**

Set dwell angle, ignition point and electrode gap with greatest accuracy to specification.  
**Engine warm.**

Check auxiliary-air device.

Test injection system

In order?

Yes

No

Check cold-start valve and thermo-switch.  
In order?

Yes

No

Check fuel pressure lines and connections.  
In order?

Yes

No

Check entire fuel system, injection valves, cold-start valve, hose connections etc. for leaks.

On vehicles with automatic transmission check setting of engine speed regulator and adjust if necessary.

Replace defective components.



# COMPONENT REMOVAL AND REPLACEMENT

In order to facilitate work in the engine compartment, it is advisable to first remove the hood.

The air filter must be removed before parts of the system can be removed.

Hold plugs on both sides when pulling them out, never pull at the cable!

When plugging-in on the individual components take care that the rubber caps are correctly pushed over the plugs.

## Pressure sensor

### Removal

The pressure sensor is installed in the R.H. side wall in the engine compartment. On vehicles with air enrichment during overrun, the vacuum limiter is installed together with the pressure sensor.

Pull off plug at pressure sensor.

Pull off vacuum hose. Fully unscrew the three fastening screws (one above, two below the pressure sensor).

Remove pressure sensor.

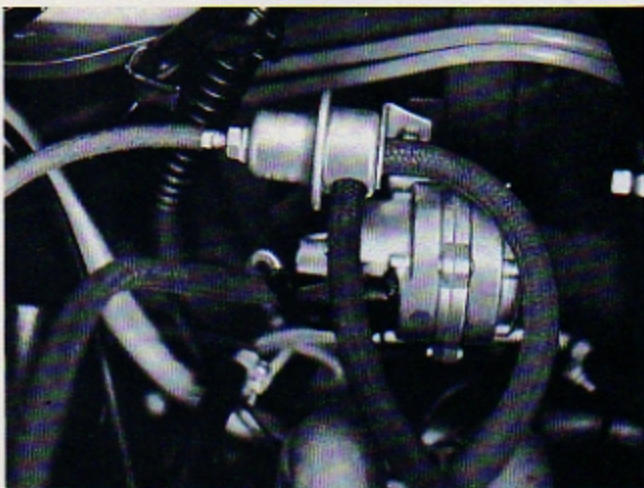

### Note for installation

The protection sleeve on the fitting of a new pressure sensor must only be removed immediately before pushing on the connecting hose as otherwise the evacuated aneroids may become contaminated. Pressure sensor must be positioned horizontally.



## Throttle valve switch

### 914/4 and 914-1.7

The throttle valve switch is fitted under the air throttle assembly.

### 914-2.0

The throttle valve switch is installed on the side of the air throttle assembly.

### Removal

#### 914/4 and 914-1.7

Remove air filter. Unhook return spring for the throttle valve. Loosen bowden cable operating the throttle valve. Screw out the two fastening screws for the air throttle assembly (arrows)

#### 914-2.0

Remove air filter, pull off plug at throttle valve switch, screw out fastening screws and remove throttle valve switch.

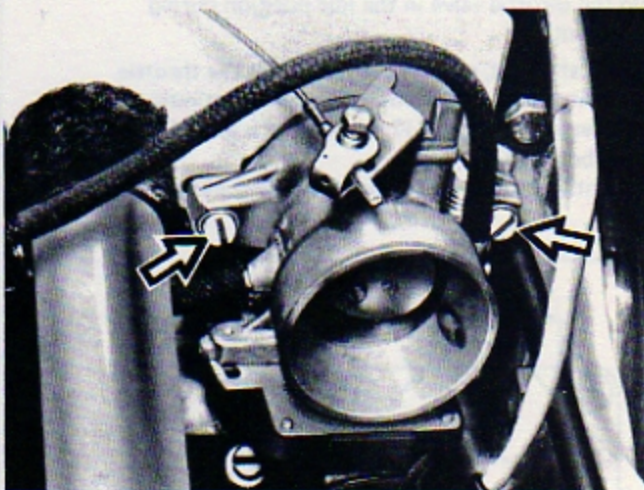

### Adjustment

USA model up to and including July 1971.

Air throttle assembly removed:

Connect meter between terminals 17 and 47.

Push switch onto throttle shaft and tighten the two fastening screws slightly.

Turn switch until the indicator needle of the tester moves from the "∞" position to "0".

Turn switch one graduation = 2° counterclockwise from this position and tighten.

Finally, check setting by operating the throttle valve.



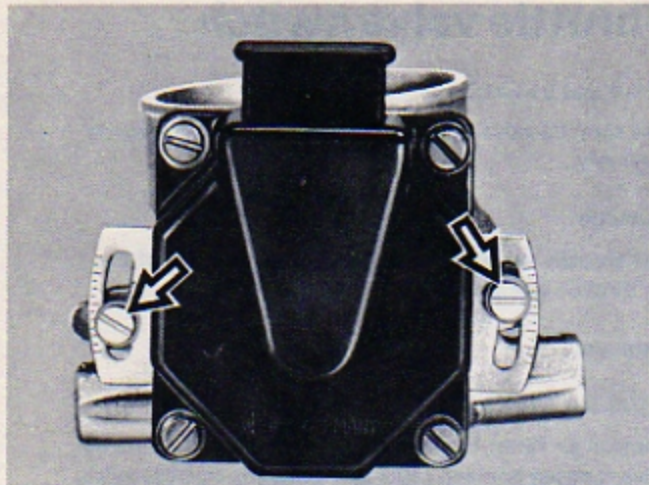

Throttle valve switch 0 280 120 021 as from FD 323  
Throttle valve switch 0 280 120 032 as from FD 321

Loosen the fastening screws. Turn the switch in a clockwise direction until an inner stop is felt. Tighten the fastening screws.

**Note:**

Hold the throttle valve in the idle position during adjustment.

In cases of doubt, remove the plug from the throttle valve switch and with ohmmeter check continuity between terminals 14 and 17 when valve is closed. Reading should be "0"  $\Omega$ .

On slightly opening valve, the instrument must indicate " $\infty$ ".

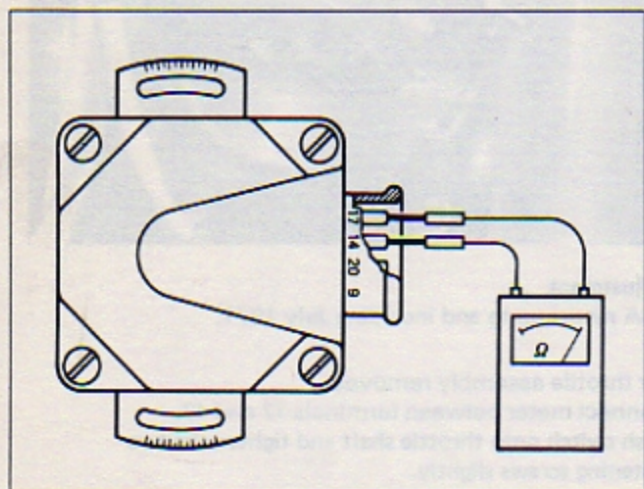

**Install air throttle assembly:**

When installing, pay particular attention to the correct positioning of the rubber sleeve (arrow).

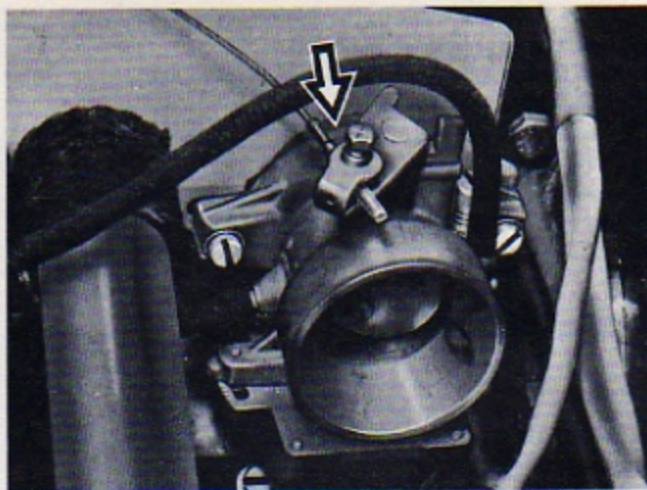

## Pressure regulator

The pressure regulator is located to the left of the cyl. 1 spark plug and is attached to a bracket.

To remove it, clamp off the two fuel lines, open the hose clamps and detach the fuel hoses.

Unscrew fastening nut, using a 17 mm open-end wrench and remove pressure regulator.

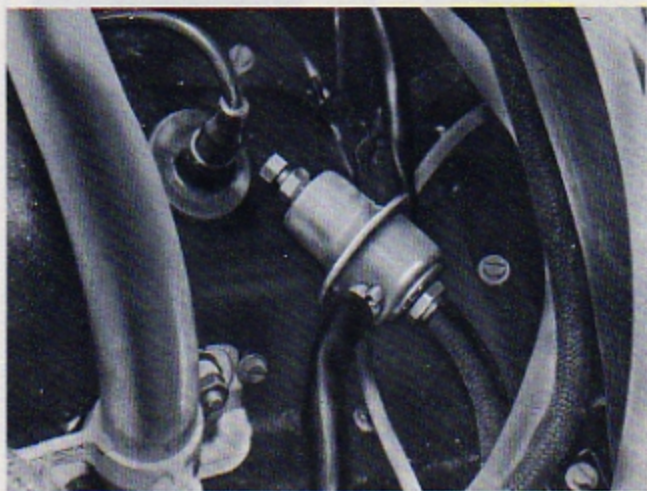

**Adjusting pressure regulator:**

The setting of the pressure regulator (and hence fuel pressure) influences the fuel consumption and the exhaust gas composition quite considerably.

For this reason, the setting should be altered only if the pressure measured varies from the checking value of 2.0–2.2 kgf/cm<sup>2</sup> (28.5–30.8 psi).

**914/4 and 914–1.7**

Connect pressure gauge to the fitting between cylinders 1 and 2.

**914–2.0**

Remove start valve and carefully detach fuel line. Connect pressure gauge with T-piece to fuel line to start valve, or remove pressure sensor and connect pressure gauge to fuel line fitting.



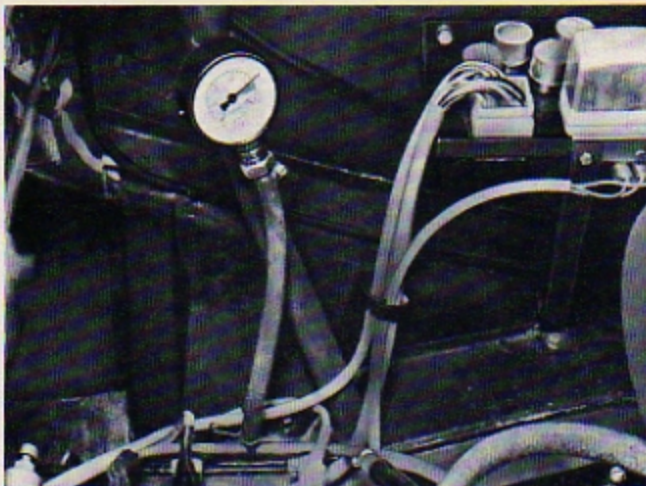

Start the engine and allow to idle. Loosen the lock nut at the pressure regulator and set the pressure to  $2.0 + 0.05 \text{ kgf/cm}^2$  ( $28.5 + 0.7 \text{ psi}$ ) by means of the hexagon head screw. Afterwards, retighten the lock nut well.

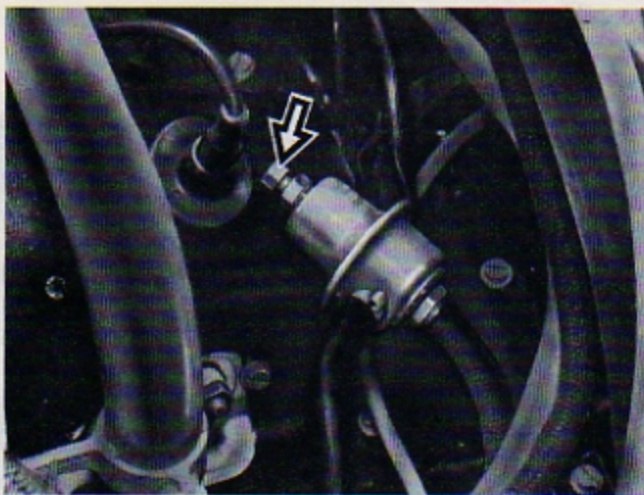

## Temperature sensor I

(intake manifold)

Remove rubber cap and 2-pole plug. Screw out temperature sensor using 13 mm open-end wrench. After installing pull protective rubber cap carefully over plug housing.



914-2.0

Temperature sensor I is installed in the top of the intake manifold.





## Temperature sensor II

(cylinder head)

The temperature sensor is screwed in below the intake tube of cyl. 4.

### Removal

Unplug the connection cable.

Remove rubber seal.

Place 13 mm tubular socket wrench over connection cable and screw out temperature sensor.

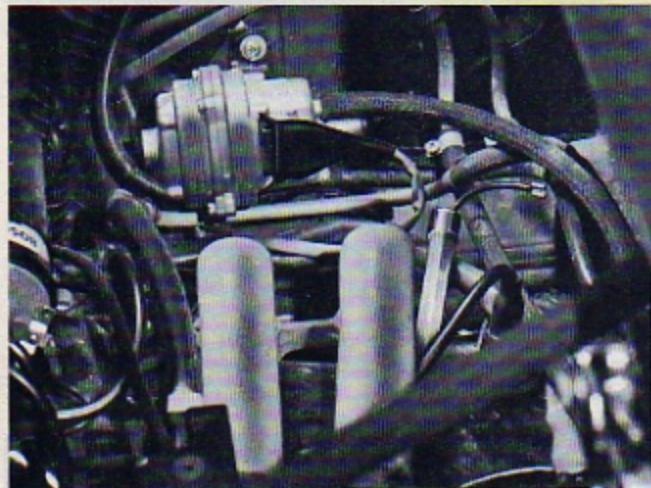

914-2.0

Temperature sensor II is located between the intake tubes.

When installing ensure that the rubber seal is correctly positioned. Insert the rubber seal in such a manner that the raised inscription faces outwards.



## Auxiliary-air device

### Removal

Screw out the two fastening screws (arrow). Draw heating element connection cable out of plug coupling (arrow). Pull off both air hoses.

Check heating element:

Resistance between connecting plug and auxiliary-air device housing:

$12.5 \pm 1.0 \Omega$  at  $+20^\circ \text{C}$  ( $68^\circ \text{F}$ ).

When installing, first fit air hoses, then fasten valve.

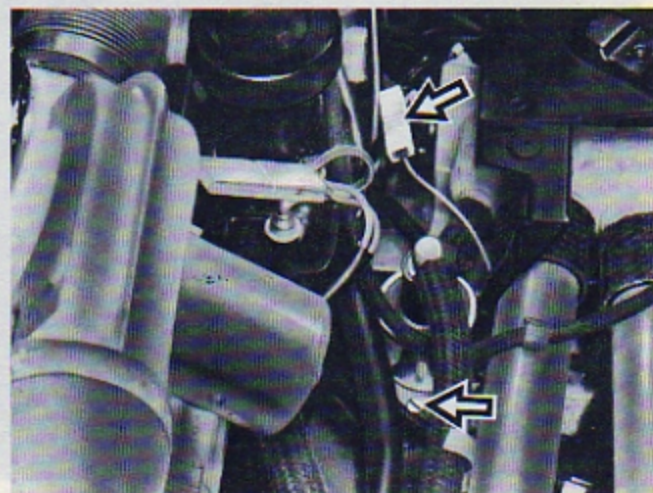

## Thermo-switch

The thermo-switch is screwed into a fastening bracket below the start valve.

Screw out thermo-switch with a 24 mm open-end wrench.

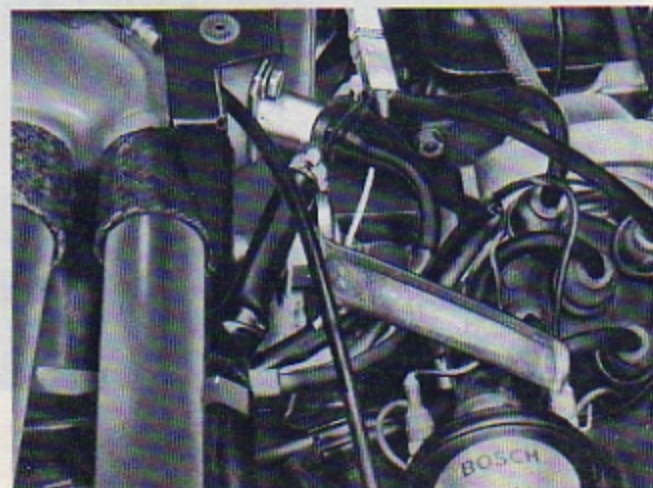



## Start valve

The start valve is fitted in the intake manifold.  
To remove, first pinch off the two fuel hoses with clamps. Cut hose clamps open. Remove valve. Carefully remove fuel lines from start valve.  
When installing, first push fuel lines onto valve and then install valve.  
Do not forget gasket!

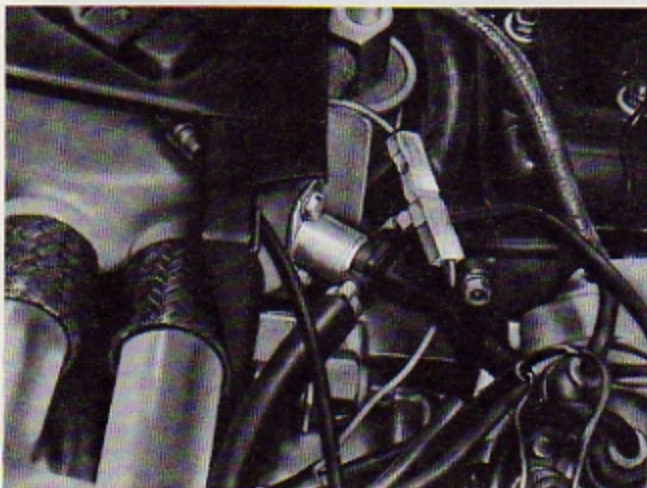

## Injection valves

When removing, it is advisable to proceed as follows:  
Loosen fastening nuts of both valves on one side.  
Check valves for correct functioning (spray test) and for leaks.  
Replace defective valve.



### Installation of the injection valves

Push injection valve holder ⑦ onto injection valve.  
Push injection valve outer locating bushing (large rubber ring) into its groove on injection valve body.  
Place injection valve inner locating bushing (rubber seal ring) on the injection valve nozzle.  
Carefully place injection valve in position and align, i. e. plug connection upwards.  
Tighten fastening nut ⑨ well.  
Push fuel hose into injection valve connection and tighten hose clamp correctly.

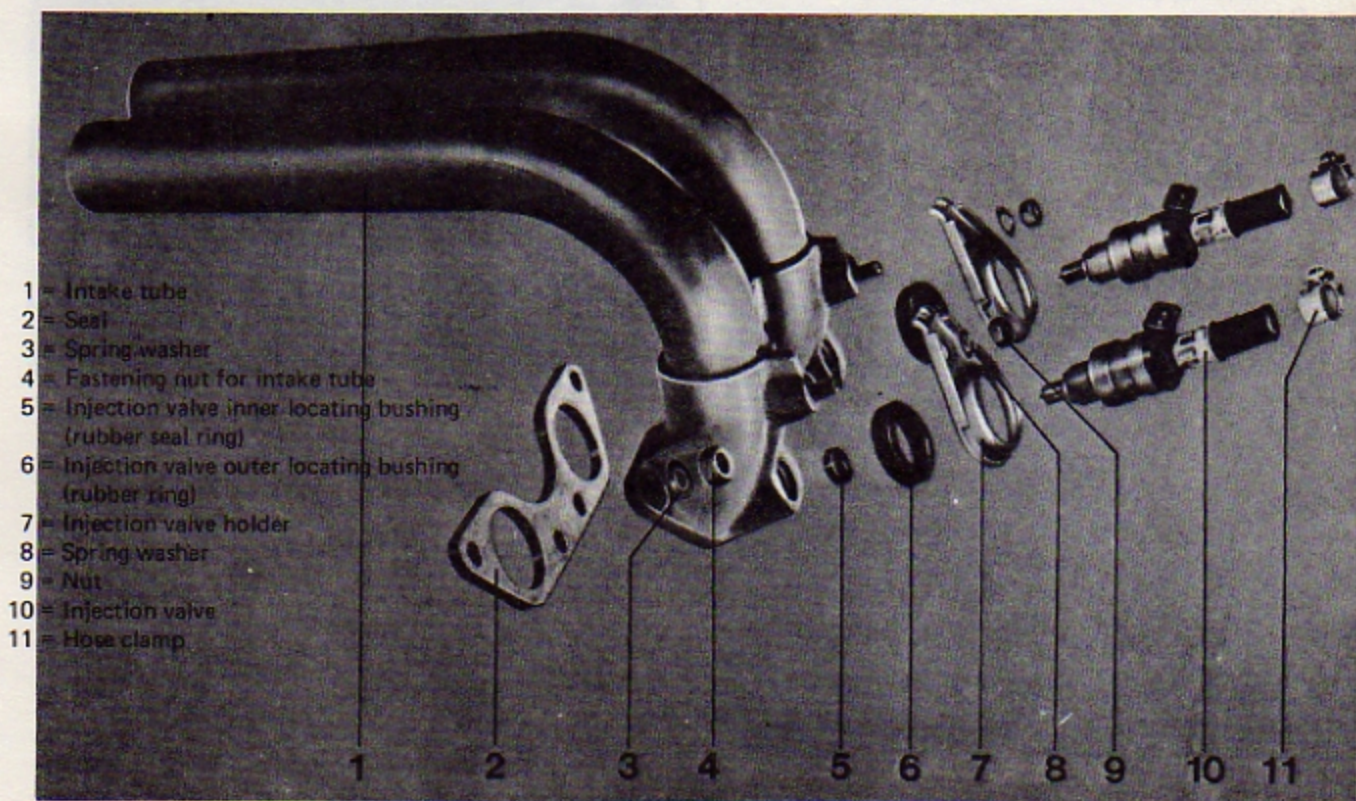



## Fuel filter

The fuel filter and fuel pump are installed on the bodywork on the right hand side, below and in front of the engine and are accessible only from below (raise vehicle).

### Removal:

up to and including July 1972

Pinch off both fuel lines to the fuel filter with clamps. Pull off hoses. Draw out filter towards the left (arrow A).



As from August 1972

Remove right-hand heater air hose. Pull off right-hand heating flaps control box from heat exchanger (do not disconnect the heater control cable). Draw out filter in upward direction. Pinch off with clamps both fuel lines to the filter. Pull off hoses.

### Installation

Replace filter every 20 000 km/12 000 miles. When installing, pay attention to direction of flow (arrow on filter housing). Take care not to damage the filter bead when inserting in the holder.

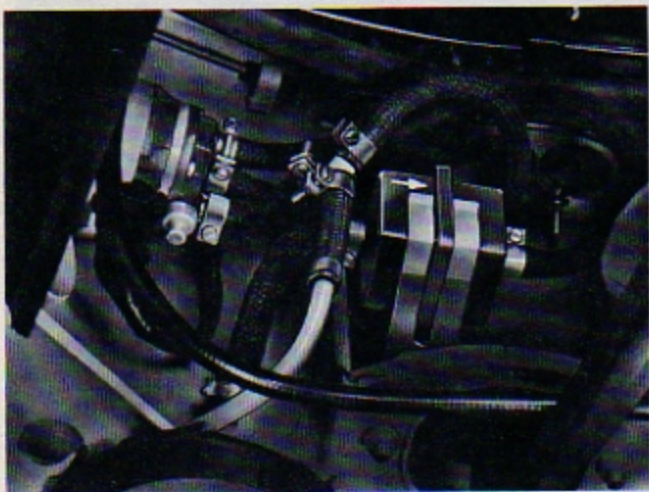

## Fuel pump

Removal: up to and including July 1972

Remove heater air hose. Pinch off with clamps fuel hoses to pump. Pull off electric plug. Loosen both fastening screws with a 10 mm socket wrench and remove pump. Do not damage rubber-bonded metal bearings when removing pump.

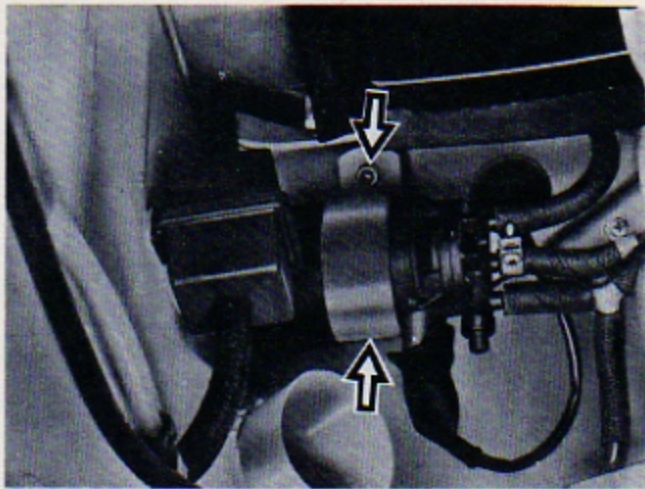

as from August 1972

Remove right-hand heater air hose. Pull off plug. Loosen M6 fastening nuts on rubber-bonded metal bearings.

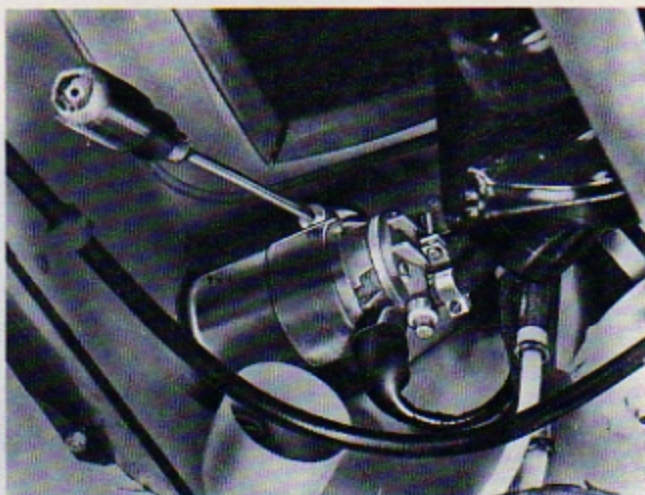



Open hose clamps of pressure, return and suction lines at fuel pump.

Pinch off fuel hoses (suction line "S" and return line "R") with commercially available clamps, pull off all fuel hoses and collect fuel which escapes.

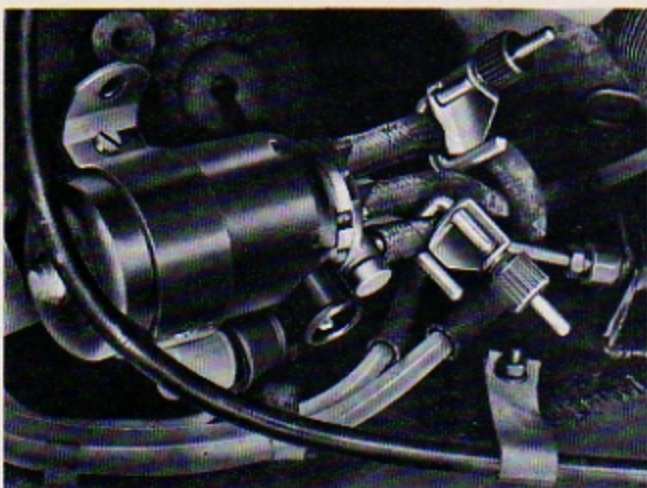

After the fuel pump has been installed, when connecting the fuel lines make sure that they are on no account interchanged!

S = Suction side  
D = Pressure side  
R = Return line

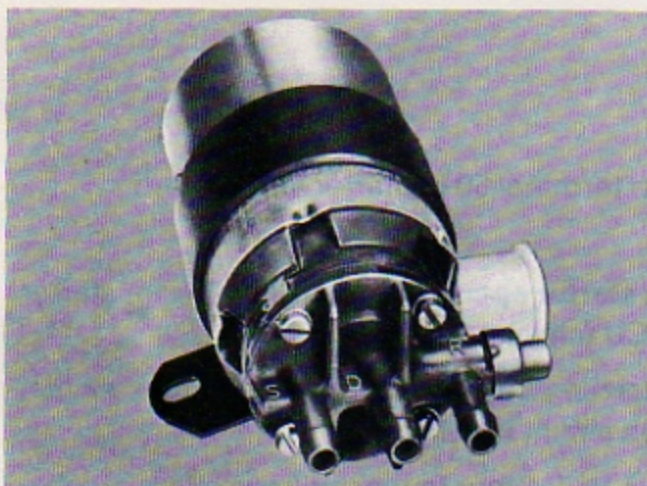

Check 2-pole plug for corrosion and replace where necessary.  
Connect 2-pole plug correctly (can only be connected in one direction) and pull rubber cap properly over the plug (arrow).

Check hose connections for leaks and correct positioning.  
Make sure that no fuel hose touches the heater air hose or the bodywork.

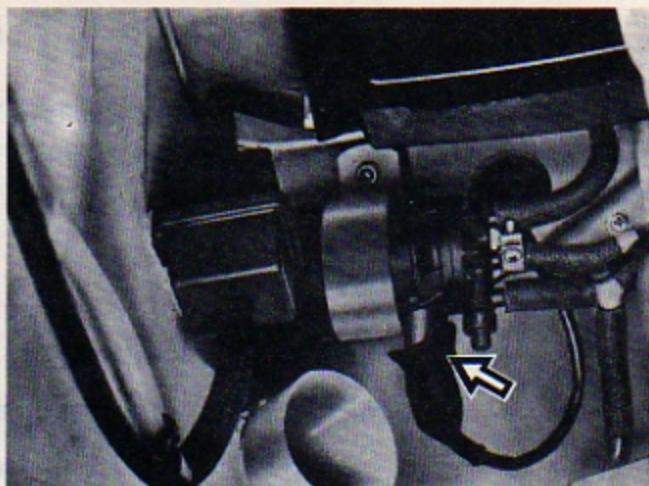

## Ignition distributor

It is advisable to remove the distributor cap before removing the distributor. Disconnect 3-pin plug from distributor. Pull the blade terminal from terminal 1 of the coil. Loosen screw on clamping bracket.

**Replace the trigger contacts:** These are mounted on a holder in the lower part of the distributor.

Loosen the two screws for the trigger contact holder on the (removed) distributor.

Take out the holder.

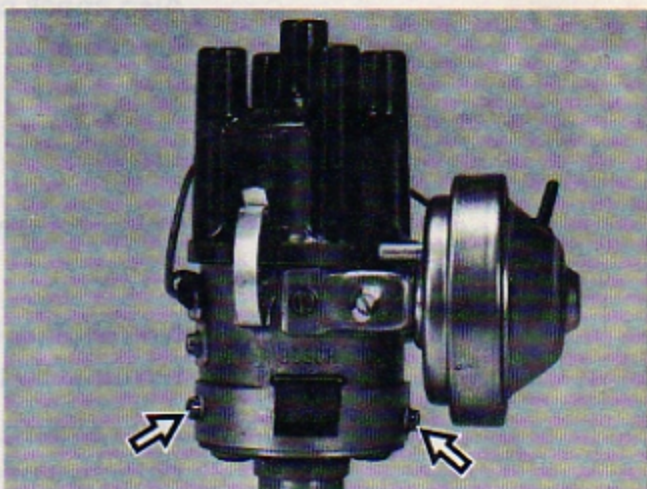

Before installing a new holder lubricate the sliding heels very lightly with Ft 1 v 4.  
It is not possible to adjust the trigger contacts.





# TEST CHART

ALL MEASUREMENTS ARE MADE ON THE TERMINALS OF THE DISCONNECTED WIRING HARNESS PLUG TO THE CONTROL UNIT (ECU) WITH IGNITION OFF UNLESS OTHERWISE INDICATED.

## Voltage Supply

**OPERATE:** Ignition.

**MEASURE:** Voltage supply to the ECU.

**VALUE:** 11-12.5 V between terminal 16 and system ground at terminal 11 of ECU plug.

**DEVIATION:** **No reading:** open circuit in cable from main relay to ECU, main relay does not energize, ignition switch defective (check for voltage at terminals 86, 30/51 and 87 of relay). Check cable 16 connecting main relay and ECU. Check cable 11 to ground.

**Voltage below 11 V:** Contact resistance in cable 16 or 11 or at relay contacts.

Also check cable 24 for voltage supply as described above for cable 16.

**OPERATE:** Starter.

**MEASURE:** Voltage between terminal 50 of starter and ground.

**VALUE:** 9-12 V.

**DEVIATION:** **No reading, but starter operates:** open circuit from starter terminal 50 to ECU (check cable 18).

**No reading, starter does not operate:** ignition switch defective or open circuit in cable.

**Voltage below 9 V:** Battery low or voltage drop in cable from ignition switch to starter terminal 50 (check cable).



# TEST CHART

## Pressure Sensor

**MEASURE:** Resistance between pressure sensor windings and ground.

**VALUE:** Infinite resistance ( $\infty\Omega$ ) between ECU plug terminal 11 (ground) and terminals 7, 8, 10 and 15 in turn.

**DEVIATION:** **Zero resistance (continuity):** Short circuit to ground in windings or cable. If meter at ECU terminals shows  $\infty\Omega$  with plug removed from sensor, replace sensor. Check cables 7, 8, 10 and 15 for short to ground.

**Resistance lower than  $\infty\Omega$  but not  $0\Omega$ :** Damage to cable insulation.

**MEASURE:** Resistance of primary windings.

**VALUE:** About  $90\Omega$  between terminals 7 and 15 of ECU plug.

**DEVIATION:** **Resistance considerably lower:** Damage to insulation. Pull plug out of sensor and if tester reads  $\infty\Omega$ , replace sensor.

**Resistance  $0\Omega$  (continuity):** Short to ground, short in primary windings. Pull plug from sensor, if meter reads  $\infty\Omega$ , replace sensor.

**Resistance considerable higher:** High contact resistance (test plugs and cables).

**Resistance  $\infty\Omega$ :** Open circuit. Bridge terminals 7 and 15 at pressure sensor plug. If tester at ECU wiring harness terminals 7 and 15 reads zero, replace pressure sensor; if  $\infty\Omega$ , check cables.

**MEASURE:** Resistance of secondary windings.

**VALUE:** About  $350\Omega$  between terminals 8 and 10 of ECU plug.

**DEVIATION:** As above under "primary windings." For resistance  $\infty\Omega$ , bridge terminals 8 and 10 at the pressure sensor plug.

**Resistance considerably higher:** High contact resistance (test plugs and cables).



# TEST CHART

## Throttle Valve Switch

**OPERATE:** Depress accelerator slowly.

**MEASURE:** Full load enrichment function.

**VALUE:** Alternating reading  $\infty/0\Omega$  with meter connected between terminal 9 and system ground at terminal 11 of ECU plug.

**DEVIATION:** If only  $0\Omega$  reading is shown, replace throttle valve switch.

**OPERATE:** Accelerator in idle position.

**MEASURE:** Function of idle contacts.

**VALUE:**  $0\Omega$  (continuity) between terminal 17 and system ground at terminal 11 of ECU plug.

**DEVIATION:** **Resistance  $\infty\Omega$ :** throttle valve switch incorrectly adjusted. Adjust according to appropriate section in "Component Removal and Replacement." Open circuit in cable (check cables). If direct reading at terminals 47 and 17 of throttle valve switch still gives infinite resistance ( $\infty\Omega$ ), replace throttle valve switch.

**OPERATE:** Accelerator slightly depressed.

**MEASURE:** Function of idle contacts.

**VALUE:**  $\infty\Omega$  between terminals 17 and 11 of ECU plug.

**DEVIATION:** **Resistance  $0\Omega$  (continuity):** throttle valve switch incorrectly adjusted or short circuit in cables. Pull plug from throttle valve switch. If meter at ECU plug still reads  $0\Omega$ , cable is defective. Otherwise adjust or replace throttle valve switch.



# TEST CHART

## Temperature Sensor I (intake manifold)

**MEASURE:** Resistance of the temperature sensor.

**VALUE:** About 300 $\Omega$  at 68°F between terminals 1 and 13 of ECU plug. At 14°F, 860-1200 $\Omega$ ; at 68°F, 260-340 $\Omega$ ; at 122°F, 90-130 $\Omega$ .

**DEVIATION:** If meter reads  $\infty\Omega$ , check sensor directly at plug. If sensor checks out OK, replace cables. If tester shows 0 $\Omega$  (continuity) at sensor terminals, replace sensor.

If meter reads 0 $\Omega$ , pull plug from sensor. If meter then reads  $\infty\Omega$ , replace sensor. Otherwise replace cables.

## Temperature Sensor II (cylinder head)

**MEASURE:** Resistance of the temperature sensor.

**VALUE:** About 2.5k $\Omega$  at 68°F between ECU plug terminals 11 (ground) and 23. At 14°F, 7-12k $\Omega$ ; at 68°F, 2-3k $\Omega$ ; at 122°F, .68-1k $\Omega$ .

**DEVIATION:** As above for Temperature Sensor I.

## Trigger Contacts In Distributor

**OPERATE:** Starter to turn engine over.

**MEASURE:** Correct function of trigger contacts in distributor.

**VALUE:** Alternating reading between  $\infty\Omega$  and 0 $\Omega$  with meter connected between terminal 12 and terminals 21 and 22 in turn.

**DEVIATION:** If needle remains at  $\infty\Omega$  or 0 $\Omega$ , check terminals 12, 21 and 22 at the distributor. If terminals and cables to ECU are OK, replace trigger contacts.



# TEST CHART

## Injection Valves

**MEASURE:** Resistance of coil windings in valves.

**VALUE:**  $2.4\Omega$  at  $68^{\circ}\text{F}$  between system ground at ECU plug terminal 11 and terminals 3, 4, 5 and 6 in turn.

**DEVIATION:** **Resistance zero:** short circuit in winding or cable. Pull plug out of injection valve; if meter at ECU plug shows  $\infty\Omega$ , replace valve, otherwise replace wiring harness.

**Resistance  $\infty\Omega$ :** open circuit in winding or cable. Check cable for continuity. If OK, replace valve.

**Resistance over  $3\Omega$ :** check ground cable from injection valves to engine.

**Visual check of injection valves:** check connections, check grey caps pointing to rear on cylinders 2 and 4, black caps towards front. Check that protective caps are pulled over plugs.



# TEST CHART

## Fuel Pump, Pressure Regulator and Relay

**OPERATE:** Turn on ignition and bridge ECU plug terminal 19 to system ground at terminal 11 to energize relays and operate fuel pump. Connect pressure gauge as described in section "Component Removal and Replacement." Gauge remains connected for all remaining test steps.

**MEASURE:** Pressure in fuel line and function of pressure regulator.

**VALUE:** 2.0–2.2 kgf/cm<sup>2</sup> (28.5–30.8 psi)

**DEVIATION:** **No pressure build-up (pump does not start):** pull plug from pump and measure voltage at plug contacts. If 12 V, pump is defective. If 0 V, check pump relay. If relay is operating, then check cable from relay terminal 87 to pump. If cables are OK, relay is defective. If relay is not operating, check cable from main relay terminal 87 to pump relay terminal 86 or from pump relay terminal 85 to cable 19 of the wiring harness (in engine compartment) for continuity. If cables check OK, replace pump relay.

**Pressure above or below 28-30 psi:** pressure regulator incorrectly adjusted; adjust as described in "Component Removal and Replacement." If adjustment not possible, replace unit.



# TEST CHART

## Leakage In System

**OPERATE:** Turn on ignition and briefly bridge terminals 19 and 11 of ECU plug to energize relays and operate fuel pump.

**MEASURE:** Leaks in fuel system.

**VALUE:** After removing terminal bridge, pressure may drop from nominal value back to .8 kgf/cm<sup>2</sup> (11.4 psi). After this, any further pressure drop must be very slow.

**DEVIATION:** **After removing bridge, pressure drops immediately to below 1 kfg/cm<sup>2</sup> (14.2 psi) or drops to zero:** leak in system from fuel pump to pressure regulator. Check all hoses and connections and injection valves for leaks. Build up pressure several times during test as required.

## Injection Valve Leakage

**Perform this test only if valves are suspected of leakage, since injectors must be removed.**

**OPERATE:** Starter and energize one set of valves at a time by bridging ECU plug terminal 16 and terminals 3, 4, 5 and 6 in turn.

**MEASURE:** Visual inspection of spray pattern.

**DEVIATION:** Check for leaks. The injector orifice may become wet, but no more than two drops should form on the valve per minute.



# TEST CHART

## Cold Start Valve And Thermo-Switch

**With engine temperature above 32-50°F.**

**OPERATE:** Starter.

**MEASURE:** Function of thermo-switch.

**VALUE:** Pressure reading on gauge should not drop perceptibly.

**DEVIATION:** If pressure falls when starter is operated, thermo-switch is defective.

**OPERATE:** Starter with thermo-switch grounded.

**MEASURE:** Function of cold-start valve.

**VALUE:** Pressure reading on gauge should drop while cold-start valve injects.

**DEVIATION:** If pressure does not drop when starter is operated, check cable 31 from cold-start valve to starter terminal 50 for continuity. If cable OK, check cold-start valve winding resistance at contacts on valve:  $4.2\Omega$  at 68°F.

**With engine temperature below 32-50°F.**

**OPERATE:** Starter (thermo-switch connected normally).

**MEASURE:** Function of thermo-switch.

**VALUE:** Pressure reading on gauge should drop slowly.

**DEVIATION:** If pressure does not drop, thermo-time switch or cold-start valve defective. Test cold-start valve as described above.



# TEST CHART

## Thermo-Time Switch

**Engine temperature above 23-41°F.**

**OPERATE:** Starter.

**MEASURE:** Function of thermo-time switch.

**VALUE:** Pressure reading on gauge should not drop perceptibly.

**DEVIATION:** If pressure falls when starter is operated, thermo-time switch is defective.

**OPERATE:** Starter with thermo-time switch terminal W grounded.

**MEASURE:** Function of cold-start valve.

**VALUE:** Pressure reading on gauge should drop while cold-start valve injects.

**DEVIATION:** If pressure does not drop when starter is operated, check cable 31 from cold-start valve to starter terminal 50. If cable OK, check cold-start valve winding resistance at contacts on valve:  $4.2\Omega$  at 68°F.

**Engine temperature below 23-41°F.**

**OPERATE:** Starter (thermo-time switch connected normally).

**MEASURE:** Function of thermo-time switch.

**VALUE:** Pressure reading on gauge must drop.

**DEVIATION:** If pressure does not drop, thermo-time switch or cold-start valve defective. Test cold-start valve as described above.

**END OF TEST. TURN OFF IGNITION AND REMOVE PRESSURE GAUGE.**



# IGNITION AND IDLE ADJUSTMENTS

## Adjusting ignition

- 27° BTDC = red notch
- 5° BTDC = black notch (only up to and including July 1971)
- TDC = 0 mark (as from August 1972)
- A = notch in cooling blower housing

Engine temperature: approx. 70° C (158° F)  
Assembly setting: 5° BTDC

Using a stroboscopic timing light set ignition point to 27° crankshaft BTDC at  $n = 3500$  rev/min (red notch).

Vacuum unit closed off at ignition distributor.

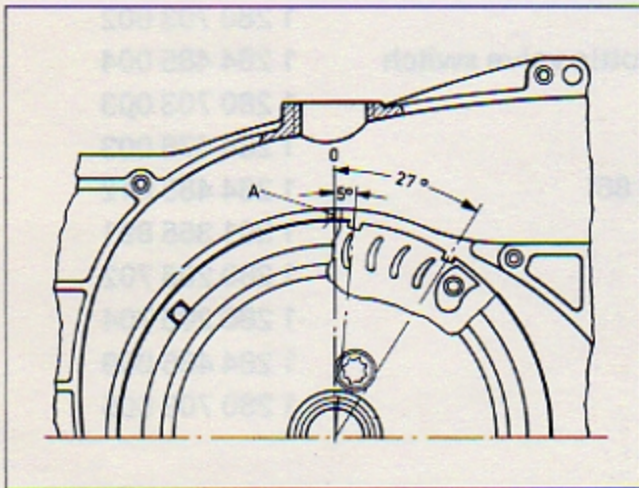

- A = notch in cooling blower housing
- 27° = red notch = setting point at  $n = 3500$  rev/min.

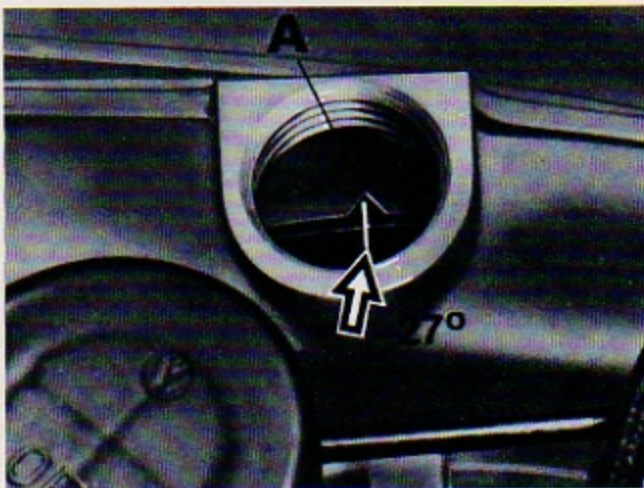

## Adjusting engine idle speed

For this adjustment, the engine must be at operating temperature (at least 70° C/158° F).

### Air filter removed!

The idle speed is set to  $900 \pm 50$  rev/min by altering the by-pass cross section with the idle adjustment screw (arrow).



**Important! The following points must be observed before starting the engine:**

1. Never let the engine run without the battery connected.
2. Never use a high speed battery charger as a starting aid.
3. When using a high speed charger to charge the battery in the vehicle, the battery should be disconnected from the rest of the electrical system.

### Starting the engine:

**Cold and warm engine: depress accelerator pedal fully, and release, before switching on ignition.**

After testing the cold-start valve, the engine must be bled before starting up, i.e. disconnect the brown cable from the main relay and then crank the engine briefly.



# SERVICE PARTS LIST

<u>Designation</u>	<u>Bosch Part Number</u>
End cover for control unit	2 285 506 000
Protective cap for potentiometer on electronic control unit	1 350 508 002
Grip on 25-pole plug	1 282 386 001
2-pole plug housing only, for injection valves, temperature sensors, cold-start valve, throttle valve switch and pressure switch	1 284 485 002
Rubber cap for 2-pole plug	1 280 703 001
3-pole plug housing only, on distributor	1 284 485 003
Rubber cap for 3-pole plug	1 280 703 002
4-pole plug housing for pressure sensor and throttle valve switch	1 284 485 004
Rubber cap for 4-pole plug	1 280 703 003
Receptacles 2.8 mm (1/8 in)	1 284 478 003
Plug housing only, for pump relay (term. 85 and 86)	1 284 485 012
Receptacles for above	1 901 355 891
Rubber ring for injection valve	1 280 206 702
Rubber seal ring for injection valve	1 280 206 704
Plug housing only, for fuel pump	1 284 485 009
Rubber cap for plug	1 280 703 005



